

iCON® Model 78CE Hydraulic Vibratory Driver/ Extractor with Model 800CE Power Unit

597 kW CAT C18 (State IIA) engine meets all EPA & EU emission regulations.
Up to 1125 kN line pull for extraction.



Full range of clamps available for sheet piling, H-Beams, pipe & caissons in addition to timber & concrete piles.

Computer controls on power unit reduce fuel consumption, pinpoint repair needs, while providing diagnostics and logs.

Power unit open circuit system for maximum cooling and filtering efficiency. Variable displacement pump for optimum power consumption and smooth operation.

Remote-control pendant for vibrator and clamp with emergency stop. Engine speed control for fuel efficiency.

The Hycos designed CE compliant hydraulic power unit oil cooler is combined with the engine cooler providing ample capacity without using auxiliary power to drive extra cooler fans.

Adaptable for underwater, low headroom or box leads operation.

Environmentally friendly, non-toxic, biodegradable hydraulic oil.

Designed and manufactured in the USA by ICE®, world leader in cost-effective foundation equipment since 1974.



iCON® Model 78CE

Hydraulic Vibratory Driver/ Extractor with Model 800CE Power Unit

Dimensions

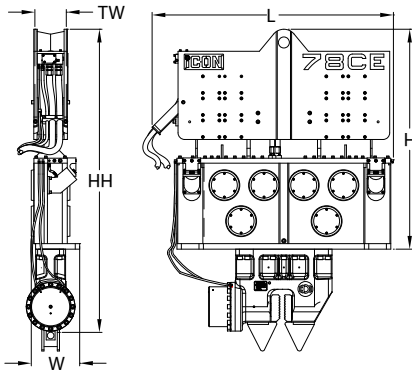

Clamps & Accessories

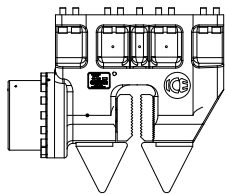

**Model 385
Universal Clamp**

Clamping force
3425 kN
Weight
2455 kg

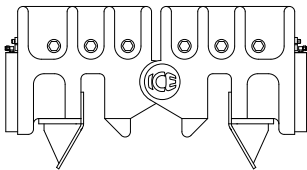

**6.5' Caisson Beam with
2 x Model 142BH Caisson Clamps**

Clamping force
1526 kN
Weight
2130 kg

Other Model 78CE Accessories

10' Clamp extension
90° Turning plate
Bias weights
Vibrator stand
Wireless remote

Model 78CE Vibrator Specifications

Eccentric moment	76 kg-m
Max. centrifugal force	2700 kN
Max. frequency	1800 rpm
Max. amplitude (no clamp)	31 mm
Max. amplitude with clamp	21 mm
Max. static line pull	1125 kN
Max. operating pressure	380 bar
Max. oil flow	1015 l/min
Dyn. weight (no clamp)	4850 kg
Dyn. weight with clamp	7305 kg
Total weight with clamp	9375 kg
Transport weight	10465 kg
Height without clamp (H)	2550 mm
Length (L)	2485 mm
Width (W)	530 mm
Throat width (TW)	362 mm

* See "Clamps and Accessories Manual" for in depth description

Model 800CE Power Unit Specifications

Engine	CAT C18
Emissions certification	EU StagIIA
Power	597 kW
Operating speed	1800 rpm
Max. motors pressure	380 bar
Motors flow (no load)	970 lpm
Clamp pressure	345 bar
Clamp flow	25 lpm
Weight (empty)	9000 kg
Length	4500 mm
Width	2200 mm
Height	2300 mm
Hydraulic reservoir	1500 liters
Fuel capacity	700 liters

iCON® Foundation Equipment
Lissenveld 69

4941VL Raamsdonksveer

+31 162 58 23 24

Hendrik de Vink & Sander Jorissen

sales@iceicon.nl

Constant improvement and engineering progress make it necessary that ICE®, Inc and iCON Foundation Equipment to reserve the right to make specification changes without notice. Please consult ICE® for the latest available information.

©International Construction Equipment, Inc. All rights reserved. January 2013.

78CE_Jan2013